



Data sheet

Technical data

Inlet connection	DN 40/50
Outlet connection	DN 40/50
Connection standard	EN 1092-2
Pump connection	DN 32/40
Pipe connection	DN 40

Materials

Material	Grey cast iron
----------	----------------

Dimensions and dimensions drawings

Accessoires mechanical

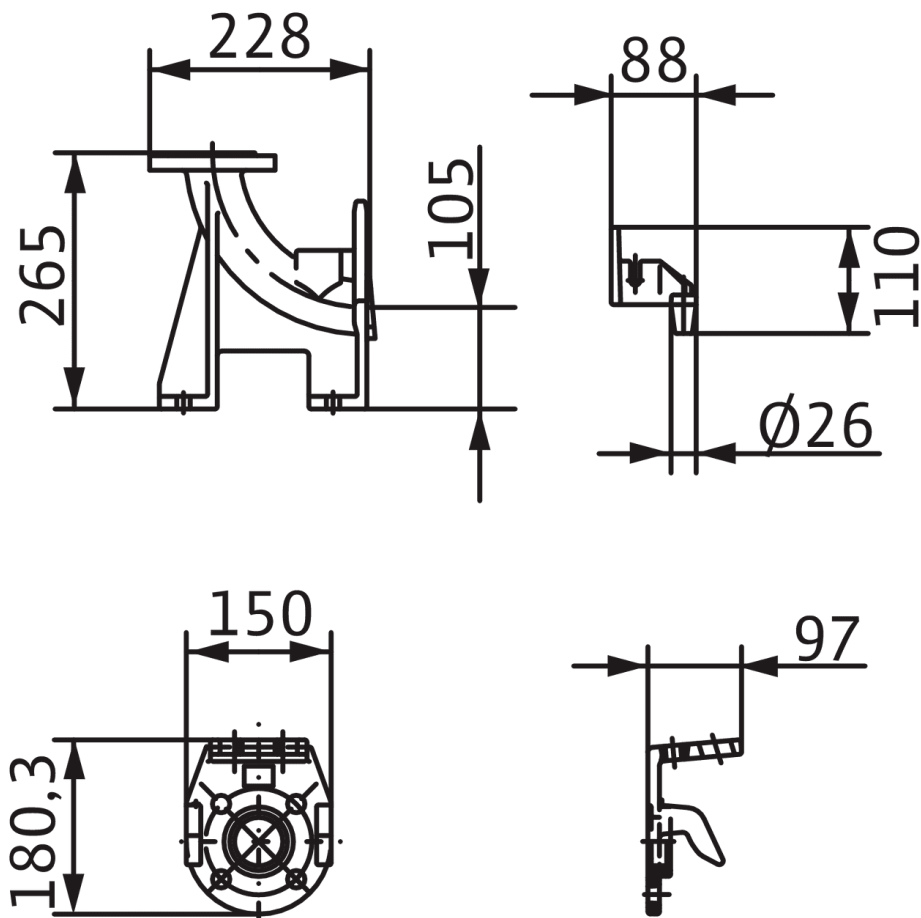

Suspension unit DN 40/50

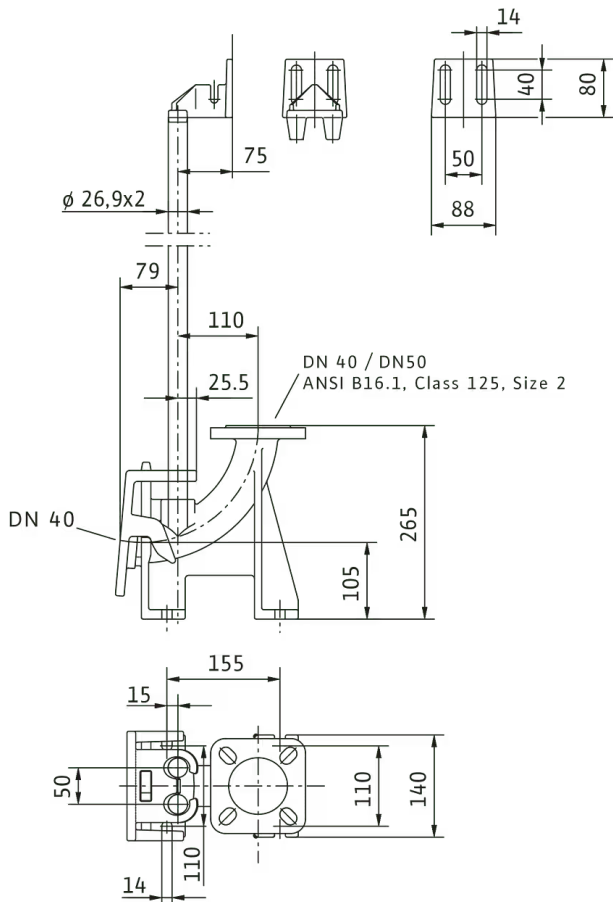

Ordering information

Product data

Brand	Wilo
Product description	Suspension unit DN 40/50
Article number	2057179
EAN number	4016322770268
Colour	grey/black
Minimum order quantity	1
Date of sales availability	2010-01-01

Packaging

Number per layer	1
Packaging property	Transport packaging
Packaging type	Cardboard box
Pieces per pallet	1

Dimension, weight

Length with packaging	370 mm
Length <i>L</i>	150 mm
Height with packaging	240 mm
Height <i>H</i>	265 mm
Width with packaging	360 mm
Width <i>W</i>	260 mm
Gross weight, approx. <i>m</i>	15.5 kg
Net weight, approx. <i>m</i>	14.5 kg

Tender text

Suspension unit for mounting in the pump chamber for easy installation of the sewage pump to the discharge pipe. scope of delivery:

- > Foot elbow with double pipe bracket
- > Coupling flange for installation on the discharge port
- > Profile joint

> Installation sundries

The two guide pipes (26.9x2 mm) are to be provided by the customer!

Technical data

Inlet connection	DN 40/50
Outlet connection	DN 40/50
Material	Grey cast iron
Net weight, approx.	14.5 kg
Make	Wilo
Item no.	2057179